



i4311

Industrial Label Printer with Portability

User Manual

Copyright and Trademarks

Disclaimer

This manual is proprietary to Brady Worldwide, Inc. (hereafter “Brady”), and may be revised from time to time without notice. Brady disclaims any understanding to provide you with such revisions, if any.

This manual is copyrighted with all rights reserved. No portion of this manual may be copied or reproduced by any means without the prior written consent of Brady.

While every precaution has been taken in the preparation of this document, Brady assumes no liability to any party for any loss or damage caused by errors or omissions or by statements resulting from negligence, accident, or any other cause. Brady further assumes no liability arising out of the application or use of any product or system described, herein; nor any liability for incidental or consequential damages arising from the use of this document. Brady disclaims all warranties of merchantability of fitness for a particular purpose.

Brady reserves the right to make changes without further notice to any product or system described herein to improve reliability, function, or design.

Trademarks

The i4311 Industrial Label Printer with Portability is a trademark of Brady Worldwide, Inc.

Microsoft, Windows, Excel, Access and SQL Server are registered trademarks of Microsoft Corporation.

Bluetooth and the Bluetooth logo are trademarks of Bluetooth SIG, Inc.

Wi-Fi is a trademark of Wi-Fi Alliance®.

Apple is a trademark of Apple Inc.

Google Play is a trademark of Google LLC.

ZPL® is a trademark of Zebra Technologies Corporation with which Brady is not affiliated.

All brand or product names referenced in this manual are trademarks (™) or registered trademarks (®) of their respective companies or organizations.

© 2025 Brady Worldwide, Inc. All Rights Reserved.

Revision A

Brady Worldwide, Inc.
6555 West Good Hope Road
Milwaukee, WI 53223
bradyid.com

Brady Warranty

Our products are sold with the understanding that the buyer will test them in actual use and determine for themselves the adaptability to their intended uses. Brady warrants to the buyer that its products are free from defects in material and workmanship, but limits its obligation under this warranty to replacement of the product shown to Brady's satisfaction to have been defective at the time Brady sold it. This warranty does not extend to any persons obtaining the product from the buyer.

THIS WARRANTY IS IN LIEU OF ANY OTHER WARRANTY, EXPRESS OR IMPLIED, INCLUDING, BUT NOT LIMITED TO, ANY IMPLIED WARRANTY OF MERCHANTABILITY OR FITNESS FOR A PARTICULAR PURPOSE, AND OF ANY OTHER OBLIGATIONS OR LIABILITY ON BRADY'S PART. UNDER NO CIRCUMSTANCES WILL BRADY BE LIABLE FOR ANY LOSS, DAMAGE, EXPENSE OR CONSEQUENTIAL DAMAGES OF ANY KIND ARISING IN CONNECTION WITH THE USE, OR INABILITY TO USE, BRADY'S PRODUCTS.

Safety and Environment

Please read and understand this manual before using the printer for the first time. This manual describes all of the main functions of the i4311 Industrial Label Printer with Portability.

Precautions

Before using the device, please note the following precautions:

- Read all instructions carefully before operating the device and prior to performing any procedure.
- Do not place the unit on an unstable surface or stand.
- Do not place anything on top of the unit.
- Keep the top clear of obstructions.
- Always use the printer in a well ventilated area. Do not block the slots and opening on the unit, which are provided for ventilation.
- Only use the power source indicated on the rating label.
- Use only the power cord that comes with the unit.
- Do not place anything on the power cord.
- This equipment is not intended for use by children.

Technical Support and Registration

Contact Information

Visit the Brady Knowledge Base at support.bradyid.com/s/.

For repair or technical assistance, locate your regional Brady Technical Support office by going to:

- **United States:** bradyid.com/techsupport
- **Canada:** bradycanada.ca/contact-us
- **Mexico:** bradyid.com.mx/es-mx/contacto
- **Latin America:** bradylatinamerica.com/es-mx/soporte-técnico
- **Europe:** bradyeurope.com/services
- **Australia:** bradyid.com.au/technical-support
- **Asia Pacific:** brady.co.uk/landing-pages/global-landing-page

Registration Information

To register your printer go to:

- bradycorp.com/register

Repair and Return

If for any reason you need to return the product for repair, please contact Brady Technical Support for repair and replacement information.

Contents

1 • Introduction

System Specifications	1
Physical and Environmental Characteristics	2
Proximity Range for Bluetooth	2
Battery	3

2 • Setup

Unpacking the Printer	4
What's in the Box	4
Registration	4
Printer Components	5
Power	7
Installing the Battery	7
Power Save Mode	8
Sleep Mode	8
Shutdown	8
Installing or Changing Supplies	9
Ribbon	9
Labels	10
Touchscreen	11
Navigation and Status	12
Material Details	12
Connecting the Printer	13
Printer Name	13
Ethernet Network	13
Wi-Fi	14
USB	15
Bluetooth*	15
Embedded Web Server	16
Installing the Printer Driver (Optional)	16
Printer Driver Settings	16
Printer Settings	18
Language	18
Keyboards	18
Units of Measure	19
Date and Time	19
Storage Location	20
Display	20
About	20
Printer Password	21
Setting	21

Changing	21
Re-setting	21
Diagnostics	22
Notifications	23
Mounting the Printer.....	23
Accessories.....	24
3 • General Operation	
Software for Creating Labels.....	25
Creating Labels.....	25
Mobile Device	25
Storing Files on the Printer.....	26
Templates	26
Printing Labels.....	27
Printing from Software or the App	28
Printing Jobs Stored on the Printer	28
Importing and Printing from a USB Drive	29
Print Adjustments.....	30
Bookmarks	30
Print Speed	30
Print Energy	31
Print Position	31
Cut Automatically	31
Print on Demand	31
Reset to Brady Defaults	32
File List	32
Searching, Sorting, Filtering, and Changing	32
ZPL Scripts.....	34
Continuous Labels	34
Graphics & Fonts	34
Help.....	35
4 • Maintenance	
Cleaning the Printer.....	36
Residue and Dust	36
The Display	37
The Cutter Blade	37
Sensors	39
The Printhead	40
Replacing the Supply Wiper	41
Label Jam	41
Installing Firmware Upgrades	42
Updating Label Library Values.....	44
Recycling the Label and Ribbon Cartridges	45
Dismantling the Ribbon Cartridge	45

Dismantling the Label Cartridge	47
---------------------------------------	----

5 • Troubleshooting

A • Regulatory Compliance

Agency Compliance and Approvals	51
United States	51
Estados Unidos	52
Canada	52
Europe	53
China 中国	53
Taiwan	54
Turkey	54
Wireless Regulatory Information	55
United States	55
Mexico	55
Canada	56
European Union	56
Japan 日本	58
Mexico	58
International	58

A • Licensing

FreeRTOS	59
Newlib	59
CMSIS	60
Apache License	60
RapidJSON	63

1 Introduction

The i4311 Industrial Label Printer with Portability has the following features:

- LabelSense™ print technology – minimize waste, maximize productivity
- Drop in a ribbon cartridge in a wide range of single-color ribbons
- Drop in a label cartridge in many colors, styles, and materials
- Convenient built-in handle for portability
- Continuous and die-cut label supplies in a variety of high-performance materials
- Connect up to four simultaneous users with Bluetooth® Low Energy 5.2
- Color touchscreen LCD display input
- Rechargeable lithium ion battery

System Specifications

- **Print Resolution:** 11.8 dot/mm, 300 dpi
- **Output label width:** 0.25 in. to 4 in. (6.4 mm to 101.6 mm)
- **Label length** (continuous): 0.25 in to 60 in. (6.4 mm to 1.5 m)
- Lightweight at under 13 lb (5.9 kg)
- Single-color job printing at 300 DPI, up to 4 in. (101.6 mm) wide and up to 60 in. (1.5 m) long.
- Transfer graphics from PC or USB flash drive. Supported graphic formats are Windows metafile (*.wmf), Bitmap (*.bmp), JPG file (*.jpg), Graphic Interchange Format (*.gif) and Portable Network Graphics (*.png).
- Two USB-A ports and two USB-C ports (one for charging)
- Automatic cutter

i4311 Industrial Label Printer with Portability supports ZPL scripting. For the list of supported commands, visit <https://www.bradyid.com/support/printer/i4311>.

Physical and Environmental Characteristics

The i4311 Industrial Label Printer with Portability (standard configuration) has the following physical and environmental characteristics:

Physical	U.S. Units	Metric Units
Dimensions	12.9" L x 9.44" W x 9.56" H	328 x 240 x 243 mm
Weight (with battery)	12.9 lb	5.9 kg

Environmental	Operation	Storage
Temperature (Printer)	40° to 110° F (4° to 43° C)	0° to 110° F (-18° to 43° C)
Relative Humidity (Printer)	20% to 90% (non-condensing)	10% to 90% (non-condensing)

Note: Consumable performance may vary.



CAUTION! Avoid using the printer near water, in direct sunlight, or near a heating device.

Proximity Range for Bluetooth

The printer should be within 65 feet (19.8 m) from the router or device to pick up the Bluetooth signal.

Note: Bluetooth is an optional feature that your site may not have chosen.

Battery



WARNING! Risk of explosion if battery is replaced by incorrect type. Only use the battery intended for this product.

The battery pack must be recycled or disposed of properly according to federal, state, and municipal regulations.



WARNING! Do not operate the printer and/or charge the battery pack in temperatures above 110° F (43° C) or below 40° (4° C).

Do not store the printer in temperatures above 110° F (43° C) or below 0° (-18° C).

Do not disassemble or mistreat the battery pack.

Do not attempt to open, damage, or replace components in the battery pack.

The battery pack should only be charged using the AC adapter provided with the printer.

Do not allow metal or other conductive materials to touch the battery terminals.



WARNING! The battery pack is not intended to be transportable. When not in use, the battery pack should be stored in the hard case, soft case, or equivalent casing to prevent possible damage.

Keep the battery pack away from sparks, flames, or other heat sources.

Keep the battery pack away from water.

Never lay objects on top of the battery pack.

Keep the battery pack out of the reach of children.



CAUTION! Only use the battery intended for this product. Using any other battery risks damaging the contacts in the battery compartment.

2 Setup

Unpacking the Printer

Carefully unpack and inspect the printer surfaces (interior and exterior) and the labeling system for possible damage during shipping.

Note: Check around the printhead and inside the enclosure covers for transportation protection and remove if found.

What's in the Box

- i4311 Industrial Label Printer with Portability Printer
- Lithium ion battery pack
- A/C Adapter Kit
- Mounting Bracket
- Quick Start Guide
- Cleaning Kit



Note: Please keep the original packaging, including the box, in case the printer must be returned.



CAUTION! If shipping the printer, consult with your transportation carrier for state, federal, municipal, and international shipping regulations regarding the lithium ion battery pack contained in the printer.

Registration

To receive free product support and updates, register your printer online at www.bradycorp.com/register or tap Help on the printer, scroll to and select Warranty Registration and scan the QR code.

Printer Components

External



- | | | | |
|---|-------------------------------|----|------------------------|
| 1 | Rear Enclosure Cover | 6 | Handle for Portability |
| 2 | Front Enclosure Cover Release | 7 | USB-A Ports |
| 3 | Touchscreen Display | 8 | USB-C Port |
| 4 | Power Button | 9 | Ethernet Port |
| 5 | Label Chute | 10 | USB-C Charging Port* |

Note: *The printer is equipped with a rechargeable lithium ion battery pack. Plugging the AC adapter into a power outlet without the battery being installed will not power the printer.

The QR Code on the front of the printer will take you to the product support page
<https://www.bradyid.com/support/printer/i4311>

Internal

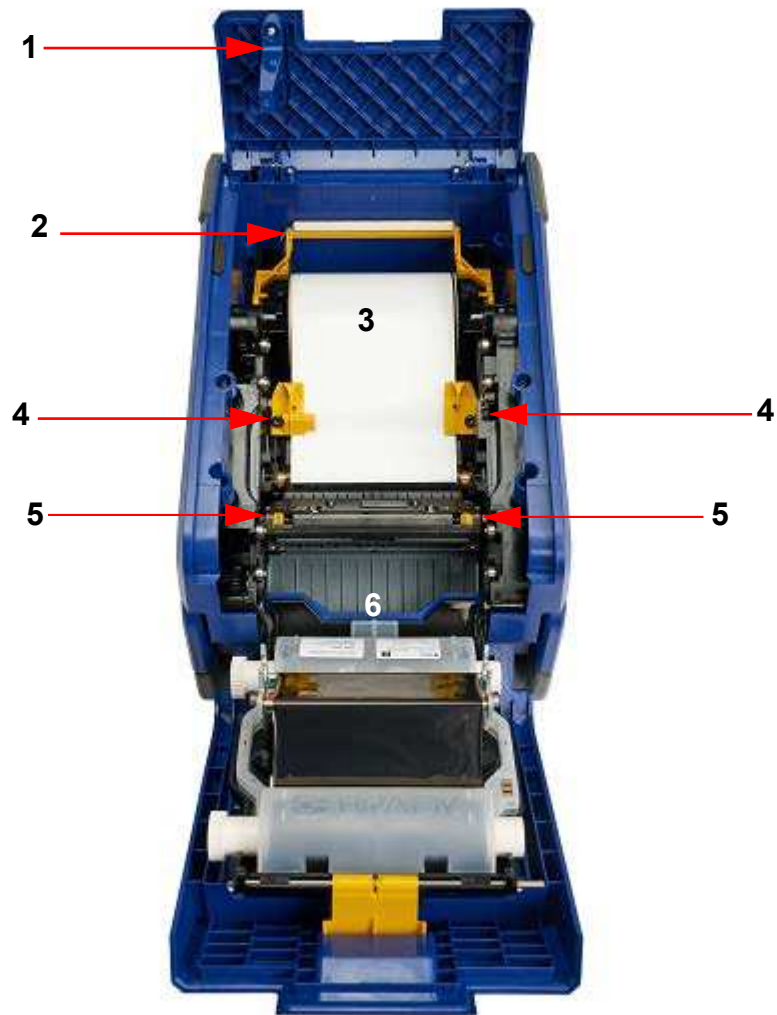

- | | | | |
|---|----------------------|---|---------------------|
| 1 | Rear Enclosure Cover | 4 | Label Guides |
| 2 | Supply Wiper | 5 | Cutter Release Tabs |
| 3 | Label Roll | 6 | Ribbon Release Tab |

Power

The printer is run by a rechargeable lithium ion battery pack. The battery pack is shipped with minimal power, so it is recommended to charge the battery prior to using the printer for the first time. After the battery is fully charged, press the power button to power on the printer.

Installing the Battery

Stand the printer up to access the bottom. Pull down on the battery cover release latch and remove cover.

With the battery label facing inward, insert battery pegs into the peg slots at the top of the compartment, then push the bottom of the battery into place.

Re-insert the tabs on the battery cover into the bottom of the compartment and snap the cover into place.



The battery indicator shown in the lower right corner of the touchscreen indicates the amount of charge left in the battery. When the battery indicator is red, there is only 20% or less battery life left.

To charge the battery in the printer:

1. Plug one end of the USB cable (included) into the charging port on the back of the printer.
2. Plug the other end into the AC adapter.
3. Plug the adapter into an AC power outlet.

When the battery is charging a + appears on the battery icon on the touchscreen.

IMPORTANT! Plugging the AC adapter into a power outlet without the battery installed will not power the printer.



To charge the battery outside the printer:

1. Remove the battery from the printer.
2. Plug one end of the USB cable (included) into the battery.
3. Plug the other end into the AC adapter.
4. Plug the AC adapter into an electrical outlet.
The light on the battery will illuminate a solid orange when charging.
5. When the light on the battery turns green, the battery is fully charged.

Power Save Mode

In order to conserve battery life the printer can be set to automatically go into power save mode after a period of inactivity.

1. Tap **Settings**.
2. Tap **System Configuration > Power Save Mode**.
3. Choose Auto Dim, to dim the display and put the printer in low power consumption or Auto Shutdown, to power off the printer after a certain amount of inactive time.
4. Slide the time indicator dot left (decrease) or right (increase) for the amount of inactive time. Alternatively, press the minus (-) button to decrease or the plus (+) button to increase the time.
5. Tap the home icon to return to the home screen.

To wake up the printer, touch the screen, tap the power button, or send a print job.

Sleep Mode

In order to conserve battery life the printer can manually be put into sleep mode. The display turns off and the system goes into the lowest power consumption state but does not require a cold start to turn back on.

To activate this mode, briefly press the power button until the display dims. When the printer is in sleep mode the power button is illuminated and the current label and settings are retained.

Press the power button to return the system to the same state it was in before going into sleep mode.

Note: In the case of an active print job, there will be a prompt to resume or cancel the job once the printer is in full power mode again.

Shutdown

To fully power off the printer press and hold the power button until the screen goes black (approximately three seconds). The power button is not illuminated when the printer is fully shutdown.

Installing or Changing Supplies

Brady ribbon cartridges and label rolls use a “smart cell” to define and track information. The system automatically recognizes the installed supplies and provides information in the lower left corner of the touchscreen.

Note: The printer can be either on or off when changing supplies.

Ribbon

1. Pull the yellow release to unlock the enclosure cover, then pull the cover towards you.
2. Pull the ribbon cartridge tab towards you and use the side handles on the ribbon cartridge to lift up and out.



3. Place the new ribbon cartridge with ribbon over printhead (product label toward machine), then snap into place.
4. Firmly close the enclosure cover.
5. If printer is in sleep mode, press the power button for the printer to detect the installed ribbon.

Labels

1. Pull the yellow release to unlock the enclosure cover, then pull the cover towards you.
2. Open the back enclosure cover.
3. Raise the yellow supply wiper, if engaged.
4. Slide the yellow label guides to fully open.
5. Remove existing labels, if installed, by grasping each side of the roll and lifting up and out.
6. Insert new label roll so that the smart cell is on the left side of the printer.



7. Feed labels from top of roll, under the yellow label guides until the leading edge sits at the middle of the black rubber platen roller.
8. Close labels guides until they touch edge of liner with labels under the guides.
9. Pull down on the supply wiper, if using continuous labels, so that it rests on the labels.

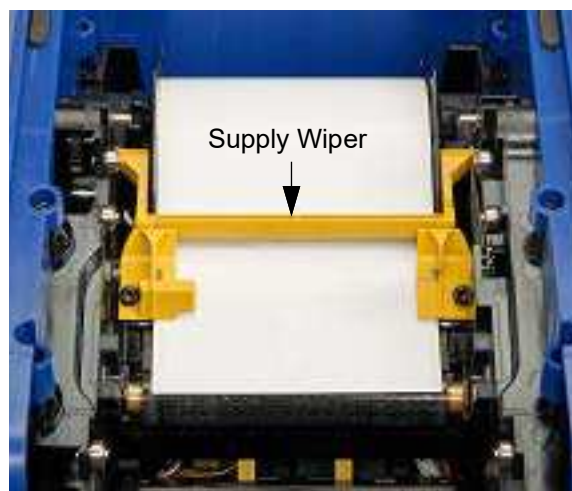

Touchscreen

Use the printer's touchscreen to configure settings, check status, and print labels, among other functions. Touch the screen with your finger to make a selection.



CAUTION! Do not use a pen or other sharp object. Doing so may damage the touchscreen surface.



1	Printer name (default is the serial number)	6	Bluetooth, available on specific models
2	Printer status	7	Ethernet connection
3	Label supply status, size and part number	8	Wi-Fi status, available on specific models
4	Ribbon supply status, size and part number	8	Clock
5	USB connection		

Navigation and Status



Home returns to the home screen.



Back arrow to go back to the previous page.



More Menu provides additional options (not available on all screens).





Download imports files from external storage to internal storage.

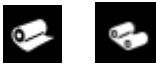

Enter used on the virtual keyboard to confirm the input data.

The printer and material status icons in the status bar at the bottom of the home screen provide the following information.

Icon	Meaning
	The text above the label icon (left) indicates the size and type of material installed. Text to the right of each icon is the order number.
	The printer cannot read the memory cell on the label roll (left icon) or the ribbon (right icon). Labels or ribbon may not be installed, may be installed incorrectly, or the memory cell may be corrupted.
 blinking	The printer is receiving data from the Brady Workstation software or the Brady Express Labels app.

Material Details

To see detailed information about the installed supplies, tap on the label or ribbon part number in the status bar to open the *Material Details* screen.



Connecting the Printer

Printer Name

The printer name is displayed when a device searches for the printer on a Wi-Fi or Bluetooth connection. If a name is not created for the printer, the default name is the serial number.

To change the printer name:

1. With the printer turned on, tap **Settings**.
2. Tap **Connection**, and then **Printer Name**.
The printer name can only contain the characters A-Z, a-z, 0-9, and -. Regardless of the keyboards you have enabled for your printer, the printer displays a keyboard with the allowed characters.
3. Use the keyboard on the touchscreen to type a name for the printer.
4. When finished tap the enter key icon on the keyboard.

When using Brady Workstation software on Wi-Fi, this name is shown when selecting a printer.

Connect to a computer in one or more of the following ways:

- Ethernet[®] network. This method allows multiple computers to send label files to the printer.
- Wi-Fi[®] wireless network (depending on your printer configuration).
- Directly with a USB cable. See [USB on page 15](#).

Note: Wi-Fi capability is not available on all printers or in all countries.

Additionally, the printer can be connected directly to the Express Labels app on your mobile device using [Bluetooth* on page 15](#).

Ethernet Network

1. On the Home screen tap **Settings**.
2. Tap **Connection**.
3. Tap **Advanced Network Settings**.
4. Tap **Ethernet**.
5. Tap **IP Settings**, and then choose either DHCP or Static.
 - **DHCP:** DHCP addressing is dynamic and the system uses a DNS server to obtain the printer IP address for you.
 - **Static:** For static addressing, you must supply the printer's IP address. First, tap the back button. Press the back arrow to return to the Ethernet screen, then fill in the following information. You may need to get assistance from your network administrator.
 - **IP Address:** Enter the printer's IP address.
 - **Subnet Mask:** Enter a subnet mask if you are using one.
 - **Default Gateway:** Enter the IP address of the default gateway.
 - **DNS Server (Primary):** Enter the IP address of the primary DNS server.
 - **DNS Server (Secondary):** Enter the IP address of the secondary DNS server.

IMPORTANT! If no DNS server is being used, enter 0.0.0.0 for both the primary and secondary DNS servers.

6. Tap the **back arrow** to return to the Advanced Network Settings screen in order for the fields entered to take effect.

Note: Ethernet Data Rate = 10/100/1000 Mbps

Wi-Fi

Connect to a Wi-Fi network either by searching for and selecting a network or by manually entering the network settings. Once connected, the printer can communicate with devices on that network.

Note: Wi-Fi capability is not available on all printers or in all countries.

IMPORTANT! Before configuring the Wi-Fi connection on an enterprise network, be sure the printer is set to the current date and time. The printer may not be able to establish the connection if the date and time is not current. See [Date and Time on page 19](#).

Search to Connect

To connect to a Wi-Fi wireless network:

1. Make sure the printer is turned on.
2. Tap **Settings**.
3. On the Settings screen, select **Connection**.
4. Tap **Wi-Fi Network**.
5. Tap the switch to enable Wi-Fi.

If the switch is gray, it is off. If the switch is blue, it is on.

6. Choose a network from the list.

If needed, the printer displays a key pad for entering the password.

If the network that you wish to connect to is not in the list, the network may be hidden. Use the steps in the following section to manually enter network settings.

Manually Enter Wi-Fi Settings

Use this method for networks that are hidden.

To connect to a Wi-Fi wireless network:

1. Make sure the printer is turned on.
2. Tap **Settings**.
3. Tap **Connection**.
4. Tap **Advanced Network Settings**.
5. Select **Wi-Fi** from the list.
6. Tap **IP Settings** and then tap one of the following.
 - **DHCP:** DHCP addressing is dynamic and the system uses a DNS server to obtain the printer IP address for you.
 - **Static:** Select static addressing to manually enter the printer's IP address.

7. Tap the **back arrow** to return to the Wi-Fi screen.
8. Fill in the remaining available settings with help from your network administrator.
9. Tap **home**.

USB

To connect to a computer via USB 2.0, plug the provided USB cable into the printer and the computer. Brady Workstation software automatically detects the printer when connected via USB cable.



Note: If you are not using Brady Workstation software, you must install the printer driver which is available online at <https://www.bradyid.com/support/printer/i4311>.

Bluetooth*

The Bluetooth status light symbol is solid blue when at least one device is connected. Up to four mobile devices can be connected at a time.

To connect the printer to a mobile device via Bluetooth:

1. Turn on the printer. Bluetooth is automatically on when the printer is on.
2. Open the Brady Express Labels app on your mobile device.
 - If no other printer is currently connected to the Express Labels app, the software detects the new printer.
 - If another printer is currently connected to the Express Labels app, manually add the printer. Tap on the menu, then tap Printers, then tap the yellow + icon to add a new printer.
3. Tap the control to connect the printer. Once connected, you may change the printer name if desired.



Note: If you need to disconnect a device, use the Forget function in the Express Labels app.

*Bluetooth, available on specific models.

Embedded Web Server

The embedded web server allows remote access to printer settings. Perform diagnostics, upgrade firmware and a host of other features.

Open a browser and enter the IP address of the printer in the address bar to access the embedded web server.

Note: The device on which the embedded web server is being used must be on the same Wi-Fi or Ethernet network as the printer.

To find the printer's IP address:

1. On the printer's home screen, tap **Settings**.
2. Tap **Connection > Advanced Network Settings**.
3. Depending on the printer's setup, either choose Ethernet or Wi-Fi and look for the IP address.

Installing the Printer Driver (Optional)

If you are using Brady Workstation software, you generally do not need to install the printer driver. The exception being the Data Automation app within Brady Workstation does require the printer driver to be installed. If connecting the printer using an Ethernet connection, it is best to configure the connection before installing the driver (see [Ethernet Network on page 13](#)).

The printer driver can be downloaded from <https://www.bradyid.com/support/printer/i4311>.

1. Turn on the printer, but **do not physically connect it to the computer until prompted**.
2. Navigate to where you saved the printer driver folder and double-click on it.
3. Double-click on the printer driver executable file and follow the on-screen instructions.

Printer Driver Settings

Settings in the driver will NOT be applied to new or existing Brady Workstation labels (unless printing through Data Automation). Existing labels saved in Brady Workstation will not be affected since the preferences are saved with the label. Only labels printed through the driver will be affected by changing these settings.

To find Printer Driver Settings:

1. Click the Start button on the computer.
2. Choose **Settings**.
3. Click on **Devices**, then **Printers & Scanners**.
4. Scroll through Printers and Scanners and click on **i4311**.
5. Click the **Manage** button.

6. Click **Printing Preferences**.

Note: Most applications allow you to change these same printer driver options from their “Print” screens. The settings you apply in printing preferences will remain until they are changed. If there are multiple printers, setting the preferences in one does not apply to all.

Printer Settings

The first time you turn on the printer, instructions on the touchscreen walk you through the settings that must be configured the first time you use the printer. The following sections detail these settings should you need to change them in the future, and provide instruction on a few additional settings to consider when setting up the printer.

For an introduction to using the touchscreen, see [Touchscreen on page 11](#). For print settings see [Print Adjustments on page 30](#).

For information on power save mode, see [Power Save Mode on page 8](#).

Language

To set the language for text on the touchscreen:

1. With the printer turned on, tap **Settings**.
2. Tap **System Configuration**, then **Language**.
3. Tap the desired language. You may need to scroll to see all available languages. Touch the screen and drag your finger up or down to scroll.
4. Tap the **back arrow** to go back to the previous screen.

Keyboards

The printer displays a keyboard on the screen when you have to type data, such as when you name the printer. Because different languages use different sets of characters, you may need keyboards with different character sets. By default the printer uses the appropriate keyboard for the language setting. For example, if the printer language is set to Simplified Chinese, the printer will automatically display a keyboard with Simplified Chinese characters. If you only want to use the default keyboard, you do not need to change any keyboard settings.

To select a virtual keyboard:

1. From the home screen, tap **Settings**.
2. Tap **System Configuration**, then **Virtual Keyboard**.
A list of supported keyboards is displayed.
3. Tap the check box for each keyboard that you want to have available when using the printer.
You can select multiple keyboards. The default keyboard (that for the printer language) is shown at the top of the list and cannot be deselected. When you use the keyboard later, the default keyboard is shown. Tap the globe icon to switch to a different enabled keyboard. Each time you tap the globe icon, the display switches to another enabled keyboard.

To connect an external keyboard:

1. Plug the keyboard's USB cable into one of the USB-A ports on the back of the printer.
2. On the home screen tap **Settings**.
3. Select **External Hardware**.
4. Select **USB Keyboard** then choose the appropriate type of keyboard from the list.

Units of Measure

Set the unit of measure to inches or millimeters.

To set the unit of measure:

1. From the home screen, tap **Settings**.
2. Tap **System Configuration**, then **Measurement Units**.
3. Tap either Inches or Millimeters.
4. Tap the **back arrow** to go back to the previous screen or the home icon.

Date and Time

Set the printer's clock to the current date and time.

To set the date and time:

1. From the home screen, tap **Settings**.
2. Tap **System Configuration**, then **Date and Time**.
The left side of the screen displays the current settings.
3. To change the settings, tap the controls on the right.
 - **Set time zone:** Tap to display the different time zones available. Tap the time zone desired.
 - **Use 24-hour format:** Tap the switch to change between 24-hour format and 12-hour format with AM and PM. When the switch is red, the printer uses 12-hour format. When the switch is green, the printer uses 24-hour format.
 - **Set date:** Tap to display date controls. To change the date, either tap on an element and select a new value, or tap the arrows above or below an element.
 - **Set time:** Tap to display time controls. To change the time, either tap on an element and select a new value, or tap the arrows above or below an element.
4. Tap the **back arrow** to go back to the previous screen or the home icon.

Storage Location

Choose whether the printer accesses files from memory or from a USB drive.

To set the storage Location:

1. From the home screen, tap **Settings**.
2. Tap **System Configuration**, then **Storage Location**.
3. Tap the desired location.
 - **Internal Memory:** Choose this option if the printer is directly connected to the computer with a USB cable or on a network. When you print a label from Brady Workstation software and choose the Store option, the print file is sent to the printer's internal memory. When you tap Files on the home screen, the printer accesses the list of files from internal memory.
 - **External Storage:** Choose this option when transferring files from one i4311 Industrial Label Printer with Portability to another. Insert a USB drive into the USB port on the printer. When you print a label from Brady Workstation software, the print file is sent to the USB drive. When you tap Files on the home screen, the printer accesses the list of files from the USB drive.
4. Tap the back arrow to go back to the previous screen or the home icon.

For information on print settings, see [Print Adjustments on page 30](#) and [File List on page 32](#).

Display

Set the level of brightness for the touchscreen.

To change the brightness:

1. On the home screen tap **Settings**.
2. Tap **Display**.
3. Tap **Adjust Brightness**.
4. Use the slider or the plus and minus buttons to increase or decrease the brightness.
5. Tap the back arrow to go back to the previous screen or the home icon.

About

The About screen displays version numbers for various components of the system, including firmware.

To view system information:

1. From the home screen, tap **Settings**.
2. Tap **About**.
3. Tap the back button to go back to the previous screen or the home icon.

Printer Password

Setting

Setting a password allows you to block access to changing settings on the printer.

To set a password:

1. From the home screen, tap **Settings**.
2. Tap **Printer Password**.
3. Tap the switch to change enable a password.
If the switch is gray, it is off. If the switch is blue, it is on.
4. Tap **Set Printer Password**.
5. Enter the password, which must be 8 characters and contain at least:
 - a number
 - an uppercase letter
 - a lowercase letter
6. Tap the enter key on the virtual keyboard.
7. Re-enter the password and tap the enter key on the virtual keyboard.
8. Tap **Advanced Settings** and choose which settings will need a password to be changed.

Changing

To change an existing password:

1. From the home screen, tap **Settings**.
2. Tap **Printer Password**.
3. Tap the switch to change enable a password.
If the switch is gray, it is off. If the switch is blue, it is on.
4. Tap **Set Printer Password**.
5. Enter the existing password and tap the enter key on the virtual keyboard.
6. Enter a new password, which must be 8 characters and contain at least:
 - a number
 - an uppercase letter
 - a lowercase letter
7. Enter the new password a second time to confirm it.
8. Tap the enter key on the virtual keyboard.

Re-setting

To re-set a forgotten password:

1. From the home screen, tap **Settings**.
2. Tap **Printer Password**.

3. Tap **Forgot Password**.
4. Call Technical Support (see [Contact Information on page iv](#)).
5. Type in the Printer Key provided by Technical Support.
6. Create a new password, which must be 8 characters and contain at least:
 - a number
 - an uppercase letter
 - a lowercase letter
7. Enter the new password a second time to confirm it.
8. Tap the enter key on the virtual keyboard.

Diagnostics

Information about your system, errors, and sensors can be found under this menu. If you need to speak with Tech Support, they may ask for information found here.

To access Diagnostics:

1. From the home screen, tap **Settings**.
2. Tap **Diagnostics** and the pertinent menu across the top.
3. To export Log files to a USB drive inserted in the printer, tap on Errors followed by the export button which is shown in the lower left corner.

Notifications

Use this to suppress certain warnings on the printer.

To turn notifications off or on:

1. From the home screen, tap **Settings**.
2. Tap **Notifications**.
3. Tap the switch next to your desired selection(s) to enable or disable.
If the switch is gray, it is off. If the switch is blue, it is on.

Mounting the Printer

A mounting bracket is provided so that the printer remains stable on a moving platform, such as a cart.

IMPORTANT! The printer should only be mounted on a horizontal surface.

Use isopropyl alcohol to clean the surface where the bracket will be mounted. Allow the area to fully dry. Remove the strip over the adhesive on the back of the bracket and mount.

For a more secure installation, use #4 or M3 (metric) flat head screws with an 82° head angle and then lower the printer on to the bracket pegs.



Accessories

- AC Adapter Kit (North America): 65W-AC
- AC Adapter (Global): 65W-AC-GLOBAL
- Battery: i4311-BATT
- Soft Case: i4311-SC
- Hard Case: i4311-HC
- USB-C Cable (1.5 meters): i4311 USB-C CABLE
- Cutter Cleaning Tool: B31-CCT
- Cleaning Swabs (Swab, Single Head Foam, 6mm x 90mm): PCK-6

3 General Operation

Software for Creating Labels

Install labeling software on your computer, set up the connection to the printer, then use the software to design labels and send them to the printer.

Brady Workstation software provides a variety of apps to simplify label design and printing for Product, Wire, Laboratory, and general purpose labeling. When smart cell labels are installed in the printer, Brady Workstation auto-detects the installed label roll and automatically configures the part with one click. The printer comes with a free trial license for the Brady Workstation design and print software.

To install the design and print software:

1. Make sure your computer is connected to the Internet.
2. Go to workstation.bradyyid.com.
3. Follow the instructions on the screen to download and install the software.
4. When you run the software and open an app that requires activation, follow the instructions on the screen to activate the software. Use the license ID and password on the printed insert that came with the printer.

For other Brady Workstation software or additional licenses, go to www.workstation.bradyyid.com or contact your Brady representative.

Creating Labels

Create label files using Brady Workstation software or the Brady Express Labels app. When you first create a label file, you specify the printer. This allows the software to provide features specific to your printer. Also, the software automatically detects the ribbon and labels installed in the printer.

For operation of the printer with other software, refer to the documentation for your application.

Mobile Device

System Requirement:

- Android 10.0 or higher
- Apple iOS 15.0 or higher

To Install the Brady Express Labels app:

1. Download the app from the Apple® App Store or the Google Play™ store.
2. Connect to the printer. See [Connecting the Printer on page 13](#).
3. Create labels and print.

Storing Files on the Printer

Using Brady Workstation software, you can either send files to be printed immediately or store them on the printer to be printed when needed, right from the printer display, even if the operator does not have access to Brady Workstation. To print immediately from Brady Workstation see [Printing from Software or the App on page 28](#).

To store files on the printer:

1. Make sure the Storage Location setting on the printer is set as desired.
If set to External Storage, make sure there is a USB drive on the printer. (See [Storage Location on page 20](#))
2. In Brady Workstation software, open the file and go to the Print screen. The software provides options to either print the file or to store it on the printer.
For specifics, see the help in Brady Workstation software.
3. Choose the option to store the file on the printer.
4. Click the store button and provide a name for the file when prompted.
5. When finished, the file is saved in the specified location on the printer, either internally or on a USB drive on the printer.
To print the file see [Printing Jobs Stored on the Printer on page 28](#).

To delete a file stored on the printer:

1. From the home screen, tap **Files**.
2. Tap the file to be deleted.
The file will be highlighted.
3. Tap the **More Menu**.
4. Tap **Delete**.
5. Confirm the deletion on the pop-up screen.

Templates

Using Brady Workstation software, templates can be created which can then be filled out on the printer either using the on-board virtual keyboard, a scanner or an external keyboard.

After creating the template, store it on the printer using the instructions for [Storing Files on the Printer](#).

To fill out and print from a template:

1. From the home screen, tap **Print**.
2. Select the desired template and tap the printer icon in the top right corner.
3. Tap the prompt to use the on-board virtual keyboard, or simply start typing or scanning with an external device.
4. Fill in the fields; use the enter key on the keyboard to advance to the next field.
When the last field is populated the label will automatically print.

Printing Labels

The following table describes the controls and information on the touchscreen when a print job is running or paused.

Icon	Description
	Go to the next label.
	Go to the previous label.
	Go to the last label in the file.
	Go to the first label in the file.
	Print. Start or resume printing.
	Pause printing. If cut after each label is selected, the label currently printing when the printer is paused will finish and cut. If paused in order to replace the ribbon, a label jam error will occur. See Troubleshooting on page 49 .
label number	Displays the current position in the label file as well as the total number of labels. Tap the current label number (within a rectangle) to jump to a particular label. A keypad opens. Tap the label number on the keypad and then tap the enter button.
	Cancel. Only available when printing is paused.
	More Menu. Provides a control to turn on the print on demand feature for the current print job only. For a description of the feature see Print on Demand on page 31 .
	File info is only visible when a single file is selected. Tap it to display file information which consists of the following. <ul style="list-style-type: none"> • An image of the first label in the file. • The label type for which the file was created. • The size of the label. • The number of labels in the file. • The date the file was created. • The size of the file in bytes. You can also delete or print the file from the information screen.

As you print labels, keep the following in mind:

- How and where the printer will cut the labels. See [Cut Automatically on page 31](#).
- If there is no label or ribbon installed, printing does not start and you will be prompted to install the supplies.
- If you open the enclosure cover during the print operation, printing is paused and the message “detecting media” is displayed. After the cover is closed, an error will display. Dismiss the error, press Feed, then Cut. Print the file again.

Printing from Software or the App

The simplest printing scenario is to initiate printing in Brady Workstation software or the Express Labels App and all the labels in the file print immediately.

To print:

1. Make sure Print on Demand is set to the desired state on the printer. See [Print on Demand on page 31](#).
2. Open the print job and initiate printing.
 - With **Print on Demand OFF**: All labels in the file print without input from an operator.
 - With **Print on Demand ON**: The printer displays the labels to be printed. The operator must tap the print button on the touchscreen to print each individual label in the file.

Printing Jobs Stored on the Printer

This method is very efficient for files that get printed frequently with no edits to content or quantity. It is also ideal when you need to prevent label content from being changed. However, print settings for Brady Workstation files, denoted by the Brady icon, can be changed.

To print a job stored in internal memory:

1. Be sure the storage location on the printer is set to Internal Memory. (See [Storage Location on page 20](#))
2. Tap **Print** on the printer’s home screen.
3. Tap the file or files that you want to print.

Each file is added to the print queue in the order you select them.
For information on using the file list, see [File List on page 32](#).
4. Tap the **printer icon** in the upper right, make your selections and tap the **checkmark** to start printing.

Importing and Printing from a USB Drive

A print job can be stored onto a USB drive for additional mobility when stand-alone printing from multiple printers. Jobs stored on a USB drive can then be printed from the printer screen when the USB drive is inserted into the printer.

Store the print job on a USB drive:

1. Insert the USB drive into the USB port on your computer.
2. In Brady Workstation software, open the label file.
 - a. Configure the print settings as desired. This includes number of copies, sorting, and advanced settings such as cutting options. All of these settings are saved with the print job when it is stored on the USB drive.
 - b. Click Save As.
 - c. Browse to the drive containing the USB drive and save the print job.
3. Eject the USB drive from the computer.

Import a print job from a USB drive:

1. With a USB drive inserted into a port on the printer, tap **Files** on the home screen.
2. Select **External Storage** from the drop-down menu.

A list of compatible files on the USB drive will display.
3. Tap on each file you want to import to internal memory.
4. Tap the **Download** icon in the upper right.
5. Tap **OK** on the message.

Print directly from a USB drive:

1. Insert a USB drive with compatible print jobs into a port on the printer.
2. Tap **Print** on the home screen.
3. Tap the **More Menu**.
4. Tap **Memory Option**.
5. Select **External** then tap the **checkmark**.
6. Tap on the file(s) to print.

The file names are highlighted when active.
7. Tap the **Printer icon** in the upper right, make your selections and tap the **checkmark** to start printing.

Note: For best results it is recommended to download the files onto the printer before printing.

Print Adjustments

These settings will be used on all print jobs for the specific label and ribbon type installed.

To change print settings:

1. On the home screen tap **Settings**.
2. Tap **Print Adjustments**.
3. Tap the desired setting. See the following sections for details on each.

Note: The Reset to Brady Defaults button sets the printer back to factory defaults for all settings that pertain to the installed ribbon and labels. To reset a single setting back to default, go to the setting and click Reset Defaults.

Bookmarks

Changing any of the print settings will automatically create a bookmark. The next time those two smart products are installed the settings will be remembered and used. There is no limit to how many label/ribbon combinations can be assigned bookmarks, but there can only be one bookmark assigned for **each** label part number/ribbon part number combination.

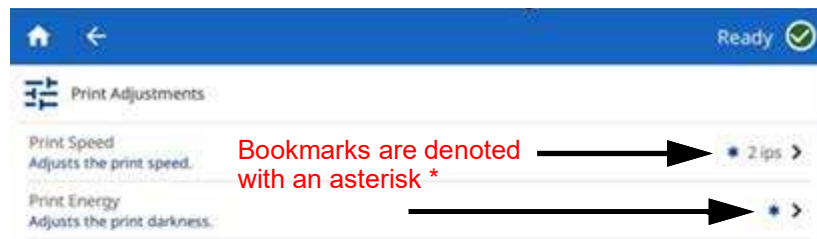

Changing or Deleting Bookmarks

Using Reset to Default within any print setting will update the existing bookmark with the new setting. To delete a bookmark, scroll to the bottom of the Print Adjustments screen and click on Reset to Brady Defaults.

Print Speed

Print speed lets you adjust the speed setting from 1 to 4 inches per second (ips). Optimal print speed settings are set automatically by the smart cell for the installed supply and should only be changed if you are experiencing problems. For example, you can change print speed if you want to print graphics or other densely populated labels more slowly to ensure complete coverage.

Use the slider to increase or decrease the speed.

Note: The selected print speed setting will stay in effect for all subsequent print jobs with the currently installed label supply. When new supply is installed, the print speed is reset to the default setting for that label or with the setting defined by a bookmark.

Print Energy

Use the slider to adjust for darker or lighter printing. Print a label to test the setting.

The print energy setting defines how much heat is applied to the printhead when printing a label. The darker the print energy, the more ink is transferred to the label. Optimal print energy settings are set automatically by the smart cell for the installed media and should only be changed if you are experiencing problems. For example, if printing is spotty you may want to increase the print energy to make sure more of the ribbon ink transfers to the label. However, if your ribbon is sticking or tearing during printing, the heat energy may be too high and should be reduced.



CAUTION! Constantly printing at high energy levels may cause printer jams or other printing errors and may reduce the overall life of your printhead.

Note: The selected print energy setting will stay in effect for all subsequent print jobs with the currently installed media. When new media is installed, the print energy level is reset to the default setting. The print energy level is also reset by rebooting the system.

Print Position

Tap the arrows to move the print in the label image left, right, up, or down.

The measurements shown in the upper right indicate how much the beginning print position will shift relative to the factory setting; it does not represent the distance from the left edge of the label. Units are in inches or millimeters depending on what units are set in [Units of Measure on page 30](#).

To reset to the factory setting (0, 0), tap reset default icon in the upper right.

Cut Automatically

Use this setting to set the cut location. Depending on the selected cut settings, the printer advances the label to cut between labels, at the end of the job, or never. If no setting is used, the default will be the cut location set in Brady Workstation.

Note: Cutting options set in Brady Workstation or a ZPL script override this setting.

Print on Demand

Print on demand causes the printer to wait for input on the touchscreen before printing the next label in the file. When disabled, all labels in a file are printed without waiting in between.

To enable print on demand:

1. From the home screen, tap **Settings**.
2. Tap **Print Adjustments**.
3. To the right of **Print on Demand**, tap the switch to change the setting.
If the switch is gray, it is off. If the switch is blue, it is on.

Reset to Brady Defaults

Selecting this option and tapping “yes” on the pop-up message will reset all print adjustments back to factory default.

File List

Use the file list to select files to see information about the files.

To use the file list:

1. Tap **Files** on the home screen to open the file list.
2. Tap the **More Menu** and select the desired location.
 - **Internal Memory** shows files residing on the printer.
 - **External Storage** shows files residing on a USB drive that is plugged in to the printer.
3. Change the file view if desired. Tap the more menu button and then tap one of the following.
 - **Thumbnail View** displays the files in a grid showing thumbnail images.
 - **List View** displays the files as a list of file names.
4. Drag your finger up or down on the screen to scroll through the list of files to find the file(s) that you want to work with. For help refining the list see [Searching, Sorting, Filtering, and Changing](#) shown below.
5. Tap a single file to select, then tap on the information icon at the top of the screen.

Searching, Sorting, Filtering, and Changing

If the list of files is long, you can find the file that you want faster by searching, sorting, or filtering the list.

To search for a label in the list:

1. With the list of files open, tap the **More Menu**.
2. Tap **Search**.
3. Use the keyboard displayed on the touchscreen to type all or part of a file name to search for. The search is not case sensitive.
4. Tap the **enter** button on the keyboard.
5. The list of files displays only files found in the search. To clear the search and display all files again, tap the X next to the search term above the list.

To sort the list:

1. With the list of files open, tap the **More Menu**.
2. Tap **Sort**.
3. Tap one of the following options.
 - **Name** sorts alphabetically by file name. Tap *Name* again to switch the sort direction between a-z or z-a.

- **Last modified** sorts by date. Tap Last modified again to switch the sort direction from newest to oldest or vice versa.
- **Number of labels** sorts by the number of labels in the file. Tap *Number of labels* again to switch the sort direction from most to least or vice versa.

4. Tap **Done**.

To filter the list by file type:

1. Tap **Files** on the home screen.
2. Tap the **More Menu**.
3. Tap **Filter** and select the type of file to filter.

Documents are label files. Graphics and fonts are used in scripts.

To change print settings:

Files generated and stored from Brady Workstation are denoted by a Brady icon. For only these files can the print settings be changed.

1. Tap **Files** on the home screen.
2. Select **Internal Memory**.
3. Select the stored file created on Brady Workstation.
4. Tap the **More Menu**.
5. Scroll down and click on **Print Settings**.
6. Change the desired settings.
7. Tap the **checkmark**, then print the file.

ZPL Scripts

The printer supports ZPL scripting with some basic commands being able to be changed directly on the printer.

To change ZPL settings:

1. Tap **Settings** on the home screen.
2. Tap **ZPL**.
3. Tap the settings to be changed.

Programming is beyond the scope of this manual.

- A ZPL specific manual that includes a list of commands that the printer supports can be found at www.bradyid/support/printer/i4311

Continuous Labels

When Brady continuous labels are installed in the printer, the ZPL script must include the [^LL] command for optimal printing. Sample script shown below.

```
^XA
^DFR:withLL2.ZPL^FS
^LL609,25
^AD,36,20^FN1^FS
^F0165,25
^AD,36,20^FN2^FS
^F025,75
^AB,22,14^FDCont with LL 2in^FS
^F025,125
^AE,28,15^FN1
^XZ
```

Graphics & Fonts

If your script files use graphics or text that are not already on the printer, you will need to import them before running the script.

Minimum Font Sizes: The printer supports a minimum 5 pt font size in scripts. If using ZPL, be aware that font sizes are not set explicitly, but rather with the bounding width and height.

IMPORTANT! It is recommended that ZPL scripts be written in the dpi supported by your printer.

Import

To import graphics and fonts from a computer to the printer, first transfer the files to a USB drive. Then follow these steps:

1. Connect the USB flash drive to any available USB port on the printer.
2. On the Home screen, tap **Files**.
3. If the screen says INTERNAL MEMORY tap it and change to **External Storage**.
4. Tap the **More Menu**.
5. Tap **Filter** and select either Images or Fonts.
6. In the list of files, tap on each file that you want to import.
7. Tap the import icon.

A progress bar will display while the import is taking place.

Note: The printer displays a low memory message if it runs out of space.

Delete

To delete graphics and fonts imported to the printer, follow these steps:

1. On the Home screen, tap **Files**.
2. If the screen says EXTERNAL MEMORY tap it and change to **Internal Memory**.
3. Tap the **More Menu**.
4. Tap **Filter** and select either Images or Fonts.
5. In the list of files, tap on each file that you want to delete.
6. Tap the **More Menu** and then tap **Delete**.

Help

Pressing the Help icon on the home screen will provide pictorial instruction for common functions, which include but are not limited to the following:

- Installing labels
- Installing the ribbon
- Cleaning the printer

Additionally, there are QR codes to take you to the regional support page as well as registering the printer for the warranty. Printer updates can also be found under Help.

4 Maintenance

Cleaning the Printer

Residue and Dust

Whenever performing any maintenance on the printer, you should also clean any residue or dust caused by the labels.

Materials Required:

- Compressed Air Bottle, purchased locally (e.g., HOSA AIR-464 Gear Duster)
- Lint-free Cloth
- Isopropyl Alcohol
- Safety Glasses



CAUTION! Always wear safety glasses when using compressed air.

1. Remove the battery and supplies from the printer.
2. With safety glasses on, spray compressed air on any parts of the printer that have built-up residue.

Note: If compressed air is not available, use a lint-free cloth lightly moistened with isopropyl alcohol and wipe off residue.

3. Use compressed air to spray all visible areas inside the printer to remove accumulated dust.
4. Use a cloth moistened with isopropyl alcohol to wipe any remaining dust from inside the printer.
5. Wipe exterior cover and frame of printer for dirt and residue.
6. Replace the ribbon and labels.
7. Close all covers and install the battery.

The Display

Materials Required

- Lint-free Cloth, non-abrasive
- Isopropyl Alcohol
- - or -
- Pre-moistened Cloth (appropriate for cleaning LCD displays)



CAUTION! Normal cleaners with ammonia, soaps, or any acids can damage the screen. Use only a lint-free cloth dampened with isopropyl alcohol.

1. Lightly moisten a lint-free cloth with isopropyl alcohol, or use a pre-moistened cloth suitable for cleaning a PC screen.
2. Gently rub the damp cloth across the screen until all of the residue is removed.

The Cutter Blade



Sharp edges. Do not touch.

Note: When cleaning the cutter, you should also clean the [Sensors on page 39](#).

Materials Required

- Cutter Cleaning Tool (included)
 - Cleaning Swabs PCK-6
 - or
 - Isopropyl Alcohol and dry swabs included with printer
1. Remove the battery and supplies from the printer.
 2. Squeeze the two yellow cutter tabs to release the cutter.
 3. Clean metal cutting blade:
 - a. If the cutting blade shows significant residue, use the cutter cleaning tool to gently scrape the residue off the cutting blade.
 - b. Moisten one of the foam swabs with the alcohol. Do not allow the alcohol to drip from the swab.
 - c. Clean cutting blade with moistened swab until all residue is removed.

- d. Clean beneath the edges of the blade housing with moistened swab. To avoid forcing residue deeper into the machine, use motions from the outer edge of the blade toward the center.
- e. Continue cleaning until no residue is visible and cleaning swabs do not become discolored.

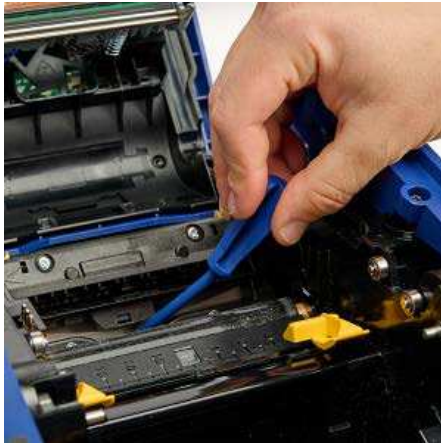

4. Close the cutting blade by pushing up on it until the cutter tabs snap into place.
5. Replace the ribbon and labels.
6. Close all covers and install the battery.

Sensors

The label and cutter sensors are located inside the printer and may be covered with dust that results from cutting the labels. One sensor is located below the yellow supply guides, as shown in the picture below. The cutter sensor is located above the cutting blade and is visible only when the cutter is released.

Materials Required

- Cleaning Swabs PCK-6
- or
- Isopropyl Alcohol and dry swabs included with printer
1. Remove the battery and supplies from the printer
 2. Squeeze the two yellow cutter tabs to release the cutter; the cutter mechanism will slide down exposing the cutter sensor.
 3. Moisten one of the foam swabs with the alcohol. Do not allow the alcohol to drip from the swab. Gently wipe the surface of the sensors at the locations shown in the picture.

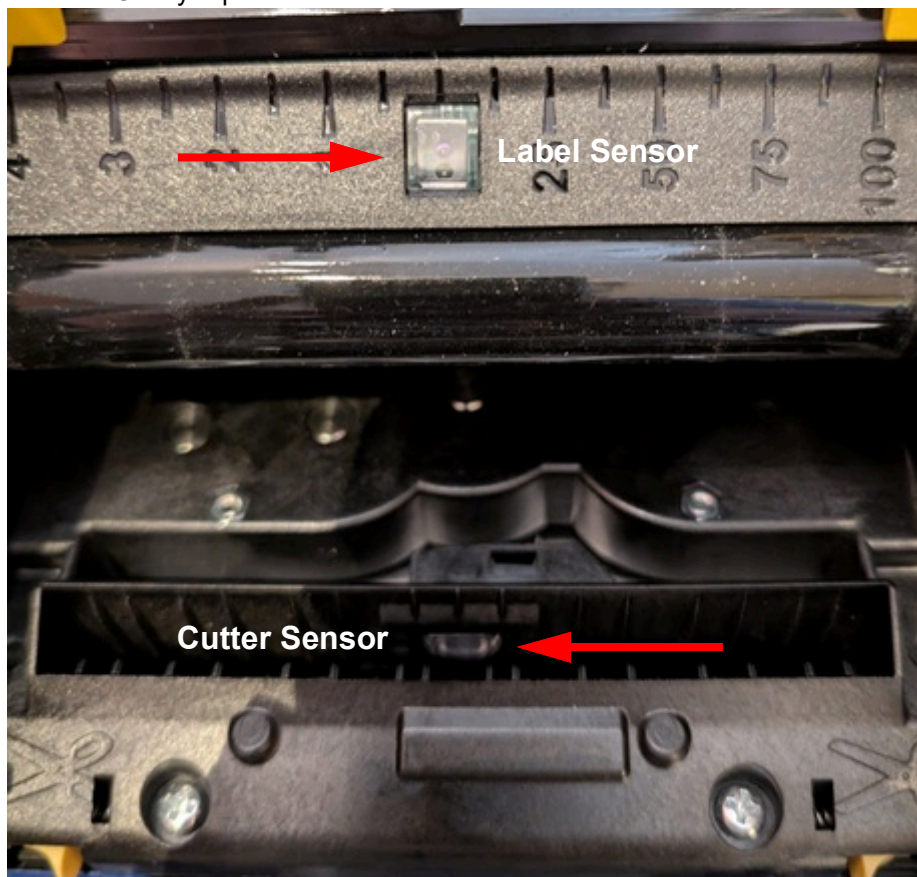

4. Replace the ribbon and labels.
5. Close all covers and install the battery.

The Printhead



Hot surface. Do not touch.



CAUTION! If the printhead is hot, allow it time to cool before proceeding.

Materials Required

- Cleaning Swabs PCK-6
- or
- Isopropyl Alcohol and dry swabs included with printer

1. Remove the battery and supplies from the printer.
2. Moisten a foam swab with the isopropyl alcohol. Do not allow the alcohol to drip from the swab.

IMPORTANT! Do **not** rub the swab over the bronze-colored area of the printhead as this could cause a short circuit.

3. Gently rub moistened swab across the green and black area of the printhead.

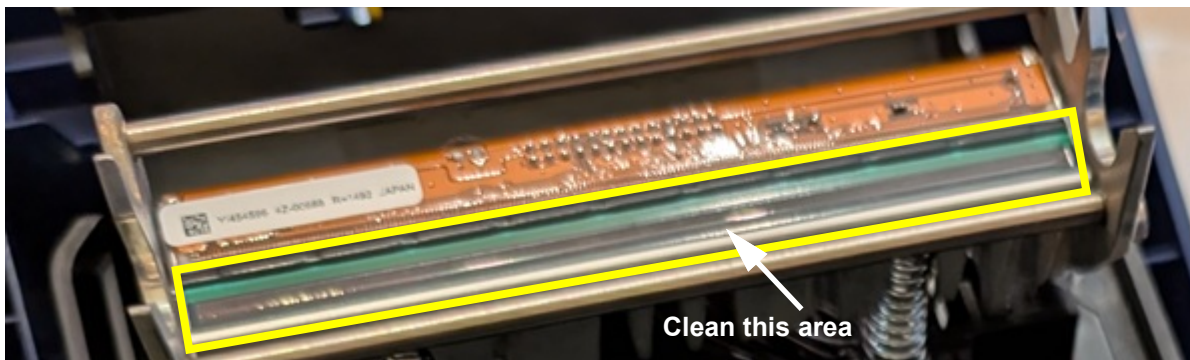

4. Replace the ribbon and labels.
5. Close all covers and install the battery.

Replacing the Supply Wiper

Materials Required

- B31-WIPER
1. Remove the battery and supplies from the printer (see [Cleaning the Printer on page 36](#)).
 2. Lift and hold the wiper arm while grasping the tab of the wiper insert [15].
 3. Pull the tab slightly forward and then slide the wiper insert out of the wiper arm.
 4. To replace the wiper, insert the lip of the wiper insert into the slot [16] of the wiper arm and slide in until the tab snaps into place.



5. Replace the ribbon and labels.
6. Close all covers and install the battery.

Label Jam

If the labels become jammed in the printer, follow these steps:

1. Open both enclosure covers.
2. Lift the label roll up and cut the labels leaving a short tail.
3. Set the roll to the side.
4. Grasp the label tail and slowly but firmly pull up and away from the printer.
5. Reinstall the label roll (see [Installing or Changing Supplies on page 9](#)).

Note: If label jam occurred while the printer was paused, see [Troubleshooting on page 49](#).

Installing Firmware Upgrades

Upgrades to firmware (printer system software) are available online. For information on how to locate the current firmware version on your printer, see [About on page 20](#).



CAUTION! Do not interrupt printer power during an upgrade.

To upgrade firmware using Brady Workstation:

1. Connect the printer with a USB cable to a computer and open Brady Workstation Software.
2. On the Brady Workstation home screen, click the **PRINTER UPDATES** link on the left-side panel and scroll to the connected printer.
Brady Workstation will automatically detect and display the current firmware on the connected printer and will display a MORE ACTIONS button.
3. Click on **MORE ACTIONS** to see options for updating firmware for the connected printer.
If upgrades are available a yellow arrow icon will be displayed.
4. Follow prompts in Brady Workstation to update the firmware for the printer.
5. When the update is complete restart the printer.

To upgrade firmware with a USB drive:

1. Insert a USB drive on your computer.
2. On the same computer, go to <https://www.bradyid.com/support/printer/i4311>.
3. Find Drivers & Firmware and click on **i4311 Firmware**.
4. Download the firmware and save it to the root of the USB drive.
5. Connect the USB drive to the USB port on the printer.
The printer recognizes the upgrade file and displays a message on the touchscreen.
6. Follow the instructions on the touchscreen.
When the upgrade is complete, the printer restarts.

To upgrade firmware through the embedded web server:

1. In a browser open the embedded web server using the printer's IP address.

Note: The device on which the embedded web server is being used must be on the same Wi-Fi or Ethernet network as the printer.

2. Navigate to **Firmware**.
3. Click **Update Now** if the version number that is available is higher than version number for the current firmware.

The firmware only for that specific printer will be updated.

Note: Upgrades via Bluetooth are not supported.

IMPORTANT! If power to the printer is interrupted during an upgrade through the embedded web server, the upgrade may not start or complete successfully. To recover, use a USB drive to finish the upgrade.

Updating Label Library Values

The printer's Label Library files are included in a database of information that enables the printer to work optimally with various supplies.

Update Label Library files periodically to make sure the printer has data for any new label supplies. Also, update if you have ordered a custom label supply from Brady and it came with new Label Library files.

To upgrade the label library using Brady Workstation:

1. Connect the printer with a USB cable to a computer and open Brady Workstation Software.
2. On the Brady Workstation home screen, click the PRINTER UPDATES link on the left-side panel and scroll to the connected printer.
Brady Workstation will automatically detect and display the current label library file on the connected printer and will display a MORE ACTIONS button.
3. Click on MORE ACTIONS to see options for updating the label library file for the connected printer.
If upgrades are available a yellow arrow icon will be displayed.
4. Follow prompts in Brady Workstation to update the printer.
5. When the update is complete restart the printer.

To upgrade the label library files using a USB drive:

1. Insert a USB drive on your computer.
2. On the same computer, go to <https://www.bradyid.com/support/printer/i4311>.
3. Find and click the Label Library link.
4. Download the database update.
5. Extract the files from the zip and save the extracted files to the root of a USB drive.
6. Connect the USB drive to the USB port on the printer and navigate to **Files > Menu** and click on "Import Printer Label Library" to launch the upgrade.
7. Follow the instructions on the touchscreen.

To upgrade the label library files through the embedded web server:

1. In a browser open the embedded web server using the printer's IP address.

Note: The device on which the embedded web server is being used must be on the same Wi-Fi network as the printer.

2. Navigate to Firmware.
3. Click Update Now if the version number that is available is higher than version number for the current label library.

The label library for that specific printer will be updated.

Note: Upgrades via Bluetooth are not supported.

Recycling the Label and Ribbon Cartridges

Cartridges need to be recycled in accordance with local regulations. Before recycling, the used cartridges must be pulled apart to release the individual components which then must be recycled in the correct recycling bins.

Materials Required:

- 9/32- inch blade or 1/4-inch blade (ribbon) and 5/32- inch blade (label) flathead screwdrivers
- Safety Glasses
- Safety Gloves



CAUTION! Always wear Personal Protective Equipment (PPE) when dismantling a cartridge.

Dismantling the Ribbon Cartridge

1. Using your thumbnail or the blade of the screwdriver, apply pressure to push the clear plastic locking tabs up until the cartridge unlocks.



2. Insert the blade of the screwdriver next to each tab along the seam of the two halves of the cartridge and gently pry apart the halves.
Repeat this process on both sides of the cartridge until all tabs are disconnected and the cartridge opens.
3. Slide the smart cell out of its location slot.
4. Unwind the ribbon from the spools and peel the ribbon end from the cardboard cores.
5. Remove the ribbon spools from the center of the cardboard core.



Recycling Components

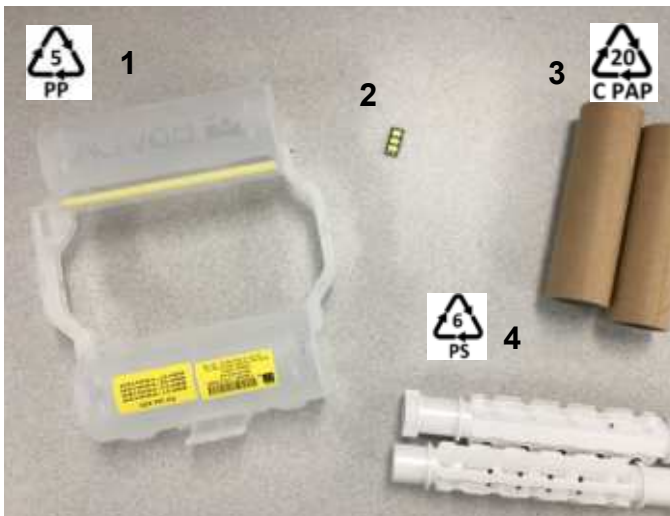

No.	Component	Material	Recycle Bin
1	Ribbon Cartridge (opaque)	PP	#5 PP
2	Smart Cell	Electronic	Electronic Waste
3	Cardboard Core	Cardboard	#20 C PAP
4	Ribbon Spools (white)	ABS	#6 PS

Dismantling the Label Cartridge

1. Using your thumbs, simultaneously apply pressure to the **release tabs** while pushing the center cylinder forward until the tabs release and unlock the center cylinder.
2. Pull the loose cylinder free from the label cartridge.
3. Using the screwdriver, place the blade in the gap next to the **smart cell holder** and pry the holder from the cylinder.
4. Remove the smart cell from the plastic holder.

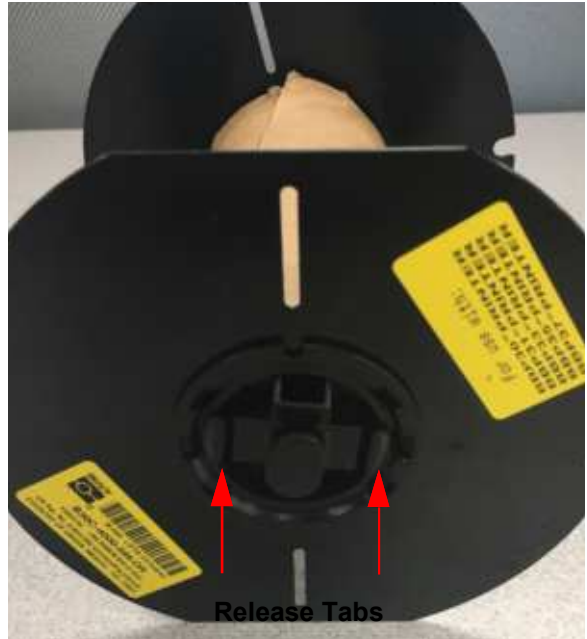

5. Push the screwdriver blade between the flat cartridge guides and **locking end cap**. Twist the screwdriver and continue this process around the end cap until comes off.
6. Repeat this process on the other side of the cartridge.
7. Remove the cardboard tube by pushing the center core out from the tube or by cutting the tube off of the core.



Recycling Components

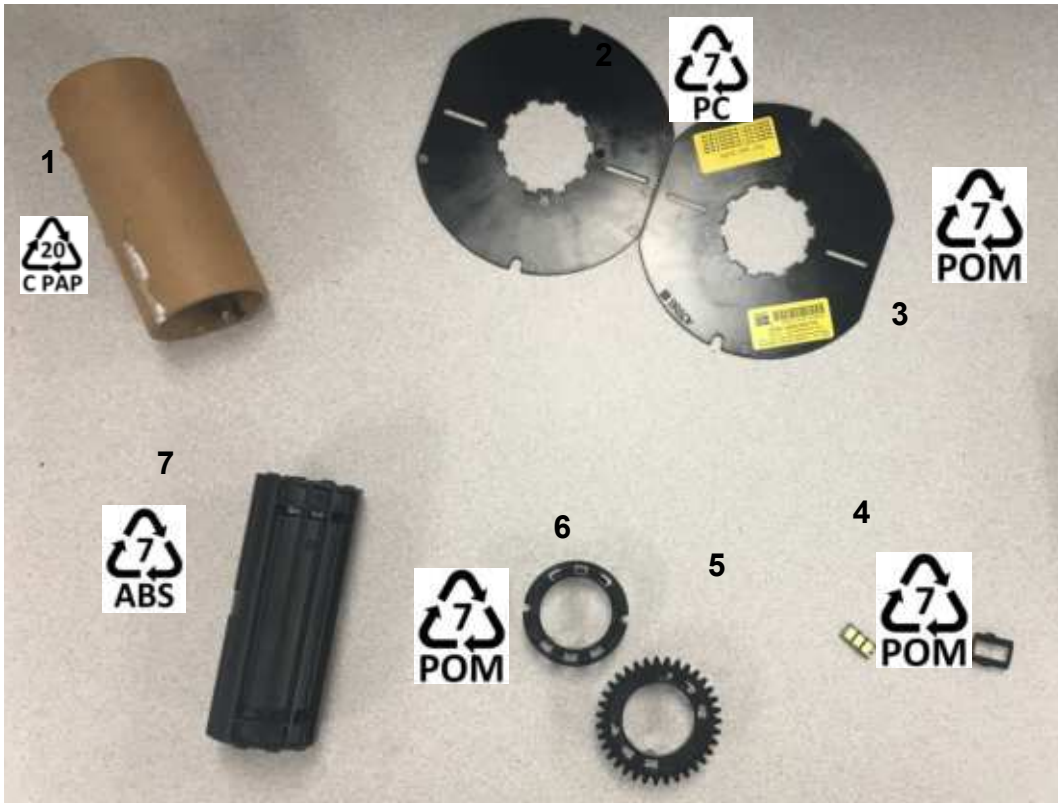

No.	Component	Material	Recycle Bin
1	Cardboard Tube	Cardboard	#20 C PAP
2	Cartridge Guides	PC	#7 PC
3	Center Cylinder	POM	#7 POM
4	Smart Cell Holder	POM	#7 POM
5	Smart Cell	Electronic	Electronic Waste
6	Locking End Caps	POM	#7 POM
7	Center Core	ABS	#7 ABS

5 Troubleshooting

Use the following table to troubleshoot problems. In situations where the printer displays an error message, follow the instructions on the touchscreen.

Problem	Cause	Corrective Action
Label Jam Error	Cover was opened during printing.	Select OK on the error message. On the home screen, press Feed . Tap Cut . If printing was paused before the cover was opened, tap Print and resume printing.
Printer does not power up when button is pressed.	Battery is dead.	Charge the battery. See Power on page 7 .
Screen freezes	User Interface error	<ol style="list-style-type: none"> 1. Press Power. 2. After printer goes to sleep, press Power again. If that doesn't work: <ol style="list-style-type: none"> 1. Completely power down the printer. 2. Wait five seconds and then power back on.
Printer will not feed labels.	<ul style="list-style-type: none"> • The leading edge of the label roll is not inserted correctly. • The leading edge of the label roll is uneven or torn (not a straight edge). 	<ul style="list-style-type: none"> • Install the labels correctly. • Cut a straight leading edge on the label roll.
Faint print on labels.	Ribbon not advancing correctly.	<ul style="list-style-type: none"> • Tension the ribbon by rotating the rewind spool (top spool) in a downward direction until all slack is removed. • Try another ribbon cartridge.
	Print energy might be too low.	Adjust the print energy setting (see Print Energy on page 31).
No print on the label.	The label or ribbon is not loaded correctly or out of ribbon.	<ul style="list-style-type: none"> • Reinstall the ribbon cartridge. • Load a new ribbon.

Problem	Cause	Corrective Action
Poor print quality.	Ribbon and labels are incompatible.	<ul style="list-style-type: none"> • Verify the correct ribbon for the label roll is loaded in the printer. • Change the ribbon or label combination.
	Dust or adhesives accumulated on the printhead.	Clean the printhead (see The Printhead on page 40).
	Supply wiper dirty.	Replace supply wiper (see Replacing the Supply Wiper on page 41).
Void areas or lines appear on printed text.	Ribbon wrinkling.	<ul style="list-style-type: none"> • Tension the ribbon by rotating the rewind spool (top spool) in a downward direction until all slack is removed. • Try another ribbon cartridge.
Cut quality is poor.	Cutter needs cleaning.	Clean the cutter (see The Cutter Blade on page 37).
Label shifts when printing frames around label causing a slight misalignment of the frame.	Label guides not adjusted correctly, producing slack that allows the labels to shift during printing.	Adjust label guides so they are snug against the labels. To make fine adjustments to the frame, (see Print Energy on page 31 .)

A Regulatory Compliance

Agency Compliance and Approvals

United States

FCC Notice

This equipment has been tested and found to comply with the limits for a Class A digital device, pursuant to part 15 of the FCC Rules. These limits are designed to provide reasonable protection against harmful interference when the equipment is operated in a commercial environment. This equipment generates, uses, and can radiate radio frequency energy and, if not installed and used in accordance with the instruction manual, may cause harmful interference to radio communications.

Operation of this equipment in a residential area may cause harmful interference in which case the user will be required to correct the interference at his own expense.

In instances where interference is experienced, the following measures are recommended to assist in mitigation:

- Reorient or reposition the equipment relative to the interference.
- Increase the separation distance between the equipment and the interference.
- Connect equipment to a separate power circuit than the interference if applicable.

Changes or modifications not expressly approved by the party responsible for compliance could void the user's authority to operate the equipment.

This device complies with Part 15 of the FCC Rules. Operation is subject to the following two conditions: (1) This device may not cause harmful interference and, (2) this device must accept any interference received, including interference that may cause undesired operation.

Estados Unidos

Aviso de la FCC

Este equipo se puso a prueba y se confirmó que cumple con los límites para un dispositivo digital de Clase A, conforme a la Parte 15 de las Regulaciones de la Comisión Federal de Comunicaciones (Federal Communications Commission, FCC). Estos límites se han diseñado para proporcionar protección razonable contra interferencias perjudiciales cuando el equipo se utilice en un entorno comercial. Este equipo genera, utiliza y puede emitir energía de radiofrecuencia y, si no se instala y se utiliza según el manual de instrucciones, puede ocasionar interferencias perjudiciales en las radiocomunicaciones.

El uso de este equipo en un área residencial puede causar interferencias perjudiciales, en cuyo caso el usuario tendrá que corregir dichas interferencias por su cuenta.

En los casos donde se producen interferencias, se recomiendan las siguientes medidas para ayudar a mitigarlas:

- Volver a orientar o reposicionar el equipo para evitar la interferencia.
- Aumente la distancia de separación entre el equipo y la interferencia.
- Si es posible, conecte el equipo a un circuito eléctrico distinto al de las interferencias.

Los cambios o las modificaciones que no hayan sido aprobados expresamente por la parte responsable del cumplimiento pueden invalidar la autorización que se le otorga al usuario para utilizar el equipo.

Este dispositivo cumple con la Parte 15 de las Regulaciones de la FCC. El uso está sujeto a las siguientes dos condiciones: (1) es posible que este dispositivo no provoque interferencias perjudiciales y (2) este dispositivo debe aceptar cualquier interferencia recibida, incluso aquella que pueda generar un uso no deseado.

Canada

Innovation, Science and Economic Development (ISED)

Canada ICES-003: Information Technology Equipment (including Digital Apparatus)

Canada NMB-003: Équipement de technologie de l'information (incluant les appareils numériques)

CAN ICES-3 (A)/NMB-3(A)

Europe



WARNING! This is a Class A product. In a domestic environment, this product may cause radio interference in which case the user may be required to take adequate measures.



Waste Electrical and Electronic Equipment Directive

In accordance with the European WEEE Directive, this device needs to be recycled in accordance with local regulations.

RoHS Directive 2011/65/EU, 2015/863/EU

This product is CE marked and complies with the European Union's Directive 2011/65/EU OF THE EUROPEAN PARLIAMENT AND OF THE COUNCIL of 8 June 2011 on the restriction of the use of certain hazardous substances in electrical and electronic equipment.

EU Directive 2015/863 of 31 March 2015 (RoHS 3) amends Annex II to Directive 2011/65/EU of the European Parliament and of the Council as regards the list of restricted substances.

Batteries Directive 2006/66/EC



This product contains a lithium coin cell battery. The crossed-out wheeled bin shown to the left is used to indicate 'separate collection' for all batteries and accumulators in accordance with European Directive 2006/66/EC. Users of batteries must not dispose of batteries as unsorted municipal waste. This Directive determines the framework for the return and recycling of used batteries and accumulators that are to be collected separately and recycled at end of life. Please dispose of the battery according to your local regulations.

Notice to Recyclers

To remove the lithium coin cell battery:

1. Disassemble printer and locate the lithium coin cell battery located on the main circuit board.
2. Using a small screwdriver, pry the battery from its holder and remove the battery from the board. Dispose of in accordance with local regulations.

China 中国

China RoHS Hazardous Substance Table related to this product is available at <https://www.bradyid.com/forms/customer-service/certificate-request>.

警告

此为 A 级产品。在生活环境中，该产品可能会造成无线电干扰。在这种情况下，可能需要用户对于干扰采取切实可行的措施。

仅适用于非热带气候条件下安全使用

仅适用于海拔2000m 以下地区安全使用。

Taiwan

Class A Statement

警告：為避免電磁干擾，本產品不應安裝或使用於住宅環境

Taiwan Restricted Substances Containment Status (RoHS Declaration) related to this product is available at <https://www.bradyid.com/forms/customer-service/certificate-request>.

Importer:

香港商貝迪香港有限公司

臺北市中山區南京東路3段101號4樓

BRADY CORPORATION HONG KONG LIMITED

4th Floor, No. 101, Section 3, Nanjing East Road, Zhongshan District, Taipei City

Turkey

Turkish Ministry of Environment and Forestry

(Directive on the Restriction of the use of certain hazardous substances in electrical and electronic equipment).

Türkiye Cumhuriyeti: EEE Yönetmeliğine Uygundur

Wireless Regulatory Information

Applies to the printer models that support wireless communication.

Regulatory markings, subject to country certification, are applied to host printer signifying Wi-Fi and Bluetooth (radio) approvals have been obtained.



WARNING! Operation of the device without regulatory approval for the region in which the equipment is being operated is illegal.

Radio protocol	WLAN IEEE 802.11a/b/g/n/ac	Bluetooth BLE
RF Operating Frequency	2400 - 2483.5 MHz W52: 5150MHz - 5250MHz and W58: 5725MHz - 5850MHz	2400 - 2483.5 MHz
Monopole PCB antenna Gain	+ 3.0 dBi @ 2.4GHz + 3.3 dBi @ 5.0GHz	
Environmental Operation Environmental Storage	-40 to 85° C (-40° to 185° F) Note: Be mindful of the maximum operating temperatures for the printer. See “Environmental Ranges” on page 2.	

United States

Note: This equipment has been tested and found to comply with the limits for a Class A digital device, pursuant to part 15 of the FCC Rules. These limits are designed to provide reasonable protection against harmful interference when the equipment is operated in a commercial environment. This equipment generates, uses, and can radiate radio frequency energy and, if not installed and used in accordance with the instruction manual, may cause harmful interference to radio communications.

Operation of this equipment in a residential area is likely to cause harmful interference in which case the user will be required to correct the interference at their own expense.

Changes or modifications not expressly approved by the party responsible for compliance could void the user's authority to operate the equipment.

This device complies with Part 15 of the FCC Rules. Operation is subject to the following two conditions: (1) This device may not cause harmful interference and, (2) this device must accept any interference received, including interference that may cause undesired operation.

Mexico

IFT notice: La operación de este equipo está sujeta a las siguientes dos condiciones: (1) es posible que este equipo o dispositivo no cause interferencia perjudicial y (2) este equipo o dispositivo debe aceptar cualquier interferencia, incluyendo la que pueda causar su operación no deseada.

Canada

Innovation, Science and Economic Development (ISED)

CAN ICES-3 (A)/NMB-3(A)

This device contains license-exempt transmitter(s)/receiver(s) that comply with Innovation, Science and Economic Development Canada's license-exempt RSSs. Operation is subject to the following two conditions:

1. This device may not cause interference; and
2. This device must accept any interference, including interference that may cause undesired operation of the device.

Le présent appareil est conforme aux CNR Innovation, Sciences et Développement économique Canada applicables aux appareils radio exempts de licence. L'exploitation est autorisée aux deux conditions suivantes:

1. l'appareil ne doit pas produire de brouillage;
2. l'utilisateur de l'appareil doit accepter tout brouillage radioélectrique subi, même si le brouillage est susceptible d'en compromettre le fonctionnement.

European Union

This is a Class A product. In a domestic environment, this product may cause radio interference in which case the user may be required to take adequate measures.

Radio Equipment Directive (RED) 2014/53/EU

- a. Frequency band(s) in which the radio equipment operates:

2.4GHz connectivity: 2400 - 2483.5MHz

5.0GHz connectivity: W52: 5150MHz - 5250MHz & W58: 5725MHz - 5850MHz

- b. Maximum radio-frequency power transmitted in the frequency band(s) in which the radio equipment operates:

2.4GHz connectivity: < +100mW EIRP

5.0GHz connectivity: W52 < +200mW EIRP, W58 < +25mW EIRP

This device is a 2.4 GHz/5.0GHz wideband transmission system (transceiver), intended for use in all EU member states and EFTA countries, except in select countries where restrictive use applies.

Country Specific Statements

български [Bulgarian] С настоящото Технология Брейди декларира, че това устройство i4311 е в съответствие със съществените изисквания и други приложими разпоредби на Директиви 2014/53/EU

Hrvatski [Croatian] Tehnologija Brady ovim putem izjavljuje da je ovaj uređaj i4311 sukladan osnovnim zahtjevima i ostalim bitnim odredbama Direktiva 2014/53/EU

Česky [Czech] Technologie Brady tímto prohlašuje, že tento i4311 je ve shodě se základními požadavky a dalšími příslušnými ustanoveními směrnice 2014/53/EU.

Dansk [Danish] Undertegnede Brady teknologi erklærer herved, at følgende udstyr i4311 overholder de væsentlige krav og øvrige relevante krav i direktiv 2014/53/EU.

Deutsch [German] Hiermit erklärt Brady-Technologie, dass sich das Gerät i4311 in Übereinstimmung mit den grundlegenden Anforderungen und den übrigen einschlägigen Bestimmungen der Richtlinie 2014/53/EU befindet.

Eesti [Estonian] Käesolevaga kinnitab Brady tehnoloogia seadme i4311 vastavust direktiivi 2014/53/EU põhinõuetele ja nimetatud direktiivist tulenevatele teistele asjakohastele sätetele.

English Hereby, Brady Technology, declares that this i4311 is in compliance with the essential requirements and other relevant provisions of Directive 2014/53/EU.

Español [Spanish] Por medio de la presente Tecnología Brady declara que el i4311 cumple con los requisitos esenciales y cualesquiera otras disposiciones aplicables o exigibles de la Directiva 2014/53/EU.

Ελληνική [Greek] ΜΕ ΤΗΝ ΠΑΡΟΥΣΑ Τεχνολογία Brady ΔΗΛΩΝΕΙ ΟΤΙ i4311 ΣΥΜΜΟΡΦΩΝΕΤΑΙ ΠΡΟΣ ΤΙΣ ΟΥΣΙΩΔΕΙΣ ΑΠΑΙΤΗΣΕΙΣ ΚΑΙ ΤΙΣ ΛΟΙΠΕΣ ΣΧΕΤΙΚΕΣ ΔΙΑΤΑΞΕΙΣ ΤΗΣ ΟΔΗΓΙΑΣ 2014/53/EU.

Français [French] Par la présente Technologie Brady déclare que l'appareil i4311 est conforme aux exigences essentielles et aux autres dispositions pertinentes de la directive 2014/53/EU.

Íslenska [Icelandic] Hér, Brady tækni, því yfir að þetta i4311 tæki er í samræmi við grunnkröfur og önnur viðeigandi ákvæði tilskipana 2014/53/ EU

Italiano [Italian] Con la presente Tecnologia Brady dichiara che questo i4311 è conforme ai requisiti essenziali ed alle altre disposizioni pertinenti stabilite dalla direttiva 2014/53/EU.

Latviešu valoda [Latvian] Aršo Brady tehnoloģija deklarē, ka i4311 atbilst Direktīvas 2014/53/EU būtiskajām prasībām un citiemar to saistītajiem noteikumiem.

Lietuvių kalba [Lithuanian] Šiuo Brady technologija deklaruoja, kad šis i4311 atitinka esminius reikalavimus ir kitas 2014/53/EU Direktyvos nuostatas.

Nederlands [Dutch] Hierbij verklaart Brady-technologie dat het toestel i4311 in overeenstemming is met de essentiële eisen en de andere relevante bepalingen van richtlijn 2014/53/EU.

Malti [Maltese] Hawnhekk, Teknoloġija Brady, jiddikjara li dan i4311 jikkonforma mal-htigijiet essenzjali u ma provvedimenti oħrajn rilevanti li hemm fid-Dirrettiva 2014/53/EU.

Magyar [Hungarian] Alulírott, Brady technológia nyilatkozom, hogy a i4311 megfelel a vonatkozó alapvető követelményeknek és az 2014/53/EU irányelv egyéb előírásainak.

Norsk [Norwegian] Herved Brady-teknologi, erklærer at denne i4311 enheten, er i samsvar med de grunnleggende kravene og andre relevante bestemmelser i direktivene 2014/53/EU

Polski [Polish] Niniejszym Technologia Brady'ego oświadcza, że i4311 jest zgodny z zasadniczymi wymogami oraz pozostałymi stosownymi postanowieniami Dyrektywy 2014/53/EU.

Português [Portuguese] Tecnologia Brady declara que este i4311 está conforme com os requisitos essenciais e outras disposições da Directiva 2014/53/EU.

Română [Romanian] Prin prezenta, Tehnologia Brady declară că acest dispozitiv i4311 este în conformitate cu cerințele esențiale și alte prevederi relevante ale Directivelor 2014/53/EU

Slovenščina [Slovenian] Tehnologija Brady izjavlja, da je ta i4311 v skladu z bistvenimi zahtevami in ostalimi relevantnimi določili direktive 2014/53/EU.

Slovenčina [Slovak] Technológia Brady týmtovyhlasuje, že i4311 spĺňa základné požiadavky a všetky príslušné ustanovenia Smernice 2014/53/EU.

Suomi [Finnish] Brady tekniikka vakuuttaa täten että i4311 tyyppinen laite on direktiivin 2014/53/EU oleellisten vaatimusten ja sitä koskevien direktiivin muiden ehtojen mukainen.

Svenska [Swedish] Härmed intygar Brady-teknik att denna i4311 står i överensstämmelse med de väsentliga egenskapskrav och övriga relevanta bestämmelser som framgår av direktiv 2014/53/EU

Japan 日本

MIC \ TELECOM: 007-AL0056

当該機器には電波法に基づく、技術基準適合証明等を受けた特定無線設備を装着している。

Mexico

IFT notice:

"La operación de este equipo está sujeta a las siguientes dos condiciones: (1) es posible que este equipo o dispositivo no cause interferencia perjudicial y (2) este equipo o dispositivo debe aceptar cualquier interferencia, incluyendo la que pueda causar su operación no deseada."

International

The Wi-Fi, BLE radio module used in Brady host printers comply with internationally recognized standards covering human exposure to electromagnetic fields, i.e. EN 62311 "Assessment of electronic and electrical equipment related to human exposure restrictions for electromagnetic fields (0 Hz - 300 GHz)".

A Licensing

FreeRTOS

Permission is hereby granted, free of charge, to any person obtaining a copy of this software and associated documentation files (the "Software"), to deal in the Software without restriction, including without limitation the rights to use, copy, modify, merge, publish, distribute, sublicense, and/or sell copies of the Software, and to permit persons to whom the Software is furnished to do so, subject to the following conditions: The above copyright notice and this permission notice shall be included in all copies or substantial portions of the Software. THE SOFTWARE IS PROVIDED "AS IS", WITHOUT WARRANTY OF ANY KIND, EXPRESS OR IMPLIED, INCLUDING BUT NOT LIMITED TO THE WARRANTIES OF MERCHANTABILITY, FITNESS FOR A PARTICULAR PURPOSE AND NONINFRINGEMENT. IN NO EVENT SHALL THE AUTHORS OR COPYRIGHT HOLDERS BE LIABLE FOR ANY CLAIM, DAMAGES OR OTHER LIABILITY, WHETHER IN AN ACTION OF CONTRACT, TORT OR OTHERWISE, ARISING FROM, OUT OF OR IN CONNECTION WITH THE SOFTWARE OR THE USE OR OTHER DEALINGS IN THE SOFTWARE.

Newlib

© Dave Nadler 2017-2020, All Rights Reserved.

Web: <http://www.nadler.com>

email: drn@nadler.com

Redistribution and use in source and binary forms, with or without modification, are permitted provided that the following conditions are met:

- Use or redistributions of source code must retain the above copyright notice, this list of conditions, and the following disclaimer.
- Use or redistributions of source code must retain ALL ORIGINAL COMMENTS, AND ANY CHANGES MUST BE DOCUMENTED, INCLUDING:
 - Reason for change (purpose)
 - Functional change
 - Date and author contact
- - Redistributions in binary form must reproduce the above copyright notice, this list of conditions and the following disclaimer in the documentation and/or other materials provided with the distribution.

THIS SOFTWARE IS PROVIDED BY THE COPYRIGHT HOLDERS AND CONTRIBUTORS "AS IS" AND ANY EXPRESS OR IMPLIED WARRANTIES, INCLUDING, BUT NOT LIMITED TO, THE IMPLIED WARRANTIES OF MERCHANTABILITY AND FITNESS FOR A PARTICULAR PURPOSE ARE DISCLAIMED. IN NO EVENT SHALL THE COPYRIGHT HOLDER OR CONTRIBUTORS BE

LIABLE FOR ANY DIRECT, INDIRECT, INCIDENTAL, SPECIAL, EXEMPLARY, OR CONSEQUENTIAL DAMAGES (INCLUDING, BUT NOT LIMITED TO, PROCUREMENT OF SUBSTITUTE GOODS OR SERVICES; LOSS OF USE, DATA, OR PROFITS; OR BUSINESS INTERRUPTION) HOWEVER CAUSED AND ON ANY THEORY OF LIABILITY, WHETHER IN CONTRACT, STRICT LIABILITY, OR TORT (INCLUDING NEGLIGENCE OR OTHERWISE) ARISING IN ANY WAY OUT OF THE USE OF THIS SOFTWARE, EVEN IF ADVISED OF THE POSSIBILITY OF SUCH DAMAGE.

CMSIS

Copyright © 2022 ARM Limited. All rights reserved.

Licensed under the Apache License, Version 2.0 (the "License"); you may not use this file except in compliance with the License.

Unless required by applicable law or agreed to in writing, software distributed under the License is distributed on an "AS IS" BASIS, WITHOUT WARRANTIES OR CONDITIONS OF ANY KIND, either express or implied. See the License for the specific language governing permissions and limitations under the License.

Apache License

Version 2.0, January 2004

<http://www.apache.org/licenses/>

TERMS AND CONDITIONS FOR USE, REPRODUCTION, AND DISTRIBUTION

1. Definitions.

"License" shall mean the terms and conditions for use, reproduction, and distribution as defined by Sections 1 through 9 of this document.

"Licensor" shall mean the copyright owner or entity authorized by the copyright owner that is granting the License.

"Legal Entity" shall mean the union of the acting entity and all other entities that control, are controlled by, or are under common control with that entity. For the purposes of this definition, "control" means (i) the power, direct or indirect, to cause the direction or management of such entity, whether by contract or otherwise, or (ii) ownership of fifty percent (50%) or more of the outstanding shares, or (iii) beneficial ownership of such entity. "You" (or "Your") shall mean an individual or Legal Entity exercising permissions granted by this License.

"Source" form shall mean the preferred form for making modifications, including but not limited to software source code, documentation source, and configuration files.

"Object" form shall mean any form resulting from mechanical transformation or translation of a Source form, including but not limited to compiled object code, generated documentation, and conversions to other media types.

"Work" shall mean the work of authorship, whether in Source or Object form, made available under the License, as indicated by a copyright notice that is included in or attached to the work (an example is provided in the Appendix below).

"Derivative Works" shall mean any work, whether in Source or Object form, that is based on (or derived from) the Work and for which the editorial revisions, annotations, elaborations, or other modifications represent, as a whole, an original work of authorship. For the purposes of this License, Derivative Works shall not include works that remain separable from, or merely link (or bind by name) to the interfaces of, the Work and Derivative Works thereof.

"Contribution" shall mean any work of authorship, including the original version of the Work and any modifications or additions to that Work or Derivative Works thereof, that is intentionally submitted to Licensor for inclusion in the Work by the copyright owner or by an individual or Legal Entity authorized to submit on behalf of the copyright owner. For the purposes of this definition, "submitted" means any form of electronic, verbal, or written communication sent to the Licensor or its representatives, including but not limited to communication on electronic mailing lists, source code control systems, and issue tracking systems that are managed by, or on behalf of, the Licensor for the purpose of discussing and improving the Work, but excluding communication that is conspicuously marked or otherwise designated in writing by the copyright owner as "Not a Contribution."

"Contributor" shall mean Licensor and any individual or Legal Entity on behalf of whom a Contribution has been received by Licensor and subsequently incorporated within the Work.

2. **Grant of Copyright License.** Subject to the terms and conditions of this License, each Contributor hereby grants to You a perpetual, worldwide, non-exclusive, no-charge, royalty-free, irrevocable copyright license to reproduce, prepare Derivative Works of, publicly display, publicly perform, sublicense, and distribute the Work and such Derivative Works in Source or Object form.
3. **Grant of Patent License.** Subject to the terms and conditions of this License, each Contributor hereby grants to You a perpetual, worldwide, non-exclusive, no-charge, royalty-free, irrevocable (except as stated in this section) patent license to make, have made, use, offer to sell, sell, import, and otherwise transfer the Work, where such license applies only to those patent claims licensable by such Contributor that are necessarily infringed by their Contribution(s) alone or by combination of their Contribution(s) with the Work to which such Contribution(s) was submitted. If You institute patent litigation against any entity (including a cross-claim or counterclaim in a lawsuit) alleging that the Work or a Contribution incorporated within the Work constitutes direct or contributory patent infringement, then any patent licenses granted to You under this License for that Work shall terminate as of the date such litigation is filed.
4. **Redistribution.** You may reproduce and distribute copies of the Work or Derivative Works thereof in any medium, with or without modifications, and in Source or Object form, provided that You meet the following conditions:
 - (a) You must give any other recipients of the Work or Derivative Works a copy of this License; and
 - (b) You must cause any modified files to carry prominent notices stating that You changed the files; and
 - (c) You must retain, in the Source form of any Derivative Works that You distribute, all copyright, patent, trademark, and attribution notices from the Source form of the Work, excluding those notices that do not pertain to any part of the Derivative Works; and
 - (d) If the Work includes a "NOTICE" text file as part of its distribution, then any Derivative Works that You distribute must include a readable copy of the attribution notices contained within such NOTICE file, excluding those notices that do not pertain to any part of the Derivative Works, in at least one of the following places: within a NOTICE text file

distributed as part of the Derivative Works; within the Source form or documentation, if provided along with the Derivative Works; or, within a display generated by the Derivative Works, if and wherever such third-party notices normally appear. The contents of the NOTICE file are for informational purposes only and do not modify the License. You may add Your own attribution notices within Derivative Works that You distribute, alongside or as an addendum to the NOTICE text from the Work, provided that such additional attribution notices cannot be construed as modifying the License.

You may add Your own copyright statement to Your modifications and may provide additional or different license terms and conditions for use, reproduction, or distribution of Your modifications, or for any such Derivative Works as a whole, provided Your use, reproduction, and distribution of the Work otherwise complies with the conditions stated in this License.

5. **Submission of Contributions.** Unless You explicitly state otherwise, any Contribution intentionally submitted for inclusion in the Work by You to the Licensor shall be under the terms and conditions of this License, without any additional terms or conditions. Notwithstanding the above, nothing herein shall supersede or modify the terms of any separate license agreement you may have executed with Licensor regarding such Contributions.
6. **Trademarks.** This License does not grant permission to use the trade names, trademarks, service marks, or product names of the Licensor, except as required for reasonable and customary use in describing the origin of the Work and reproducing the content of the NOTICE file.
7. **Disclaimer of Warranty.** Unless required by applicable law or agreed to in writing, Licensor provides the Work (and each Contributor provides its Contributions) on an "AS IS" BASIS, WITHOUT WARRANTIES OR CONDITIONS OF ANY KIND, either express or implied, including, without limitation, any warranties or conditions of TITLE, NON-INFRINGEMENT, MERCHANTABILITY, or FITNESS FOR A PARTICULAR PURPOSE. You are solely responsible for determining the appropriateness of using or redistributing the Work and assume any risks associated with Your exercise of permissions under this License.
8. **Limitation of Liability.** In no event and under no legal theory, whether in tort (including negligence), contract, or otherwise, unless required by applicable law (such as deliberate and grossly negligent acts) or agreed to in writing, shall any Contributor be liable to You for damages, including any direct, indirect, special, incidental, or consequential damages of any character arising as a result of this License or out of the use or inability to use the Work (including but not limited to damages for loss of goodwill, work stoppage, computer failure or malfunction, or any and all other commercial damages or losses), even if such Contributor has been advised of the possibility of such damages.
9. **Accepting Warranty or Additional Liability.** While redistributing the Work or Derivative Works thereof, You may choose to offer, and charge a fee for, acceptance of support, warranty, indemnity, or other liability obligations and/or rights consistent with this License. However, in accepting such obligations, You may act only on Your own behalf and on Your sole responsibility, not on behalf of any other Contributor, and only if You agree to indemnify, defend, and hold each Contributor harmless for any liability incurred by, or claims asserted against, such Contributor by reason of your accepting any such warranty or additional liability.

END OF TERMS AND CONDITIONS

RapidJSON

Copyright © 2015 THL A29 Limited, a Tencent company, and Milo Yip. All rights reserved.

If you have downloaded a copy of the RapidJSON binary from Tencent, please note that the RapidJSON binary is licensed under the MIT License.

If you have downloaded a copy of the RapidJSON source code from Tencent, please note that RapidJSON source code is licensed under the MIT License, except for the third-party components listed below which are subject to different license terms. Your integration of RapidJSON into your own projects may require compliance with the MIT License, as well as the other licenses applicable to the third-party components included within RapidJSON. To avoid the problematic JSON license in your own projects, it's sufficient to exclude the bin/jsonchecker/ directory, as it's the only code under the JSON license.

A copy of the MIT License is included in this file.

Other dependencies and licenses:

Open Source Software Licensed Under the BSD License:

The msinttypes r29

Copyright © 2006-2013 Alexander Chemeris

All rights reserved.

Redistribution and use in source and binary forms, with or without modification, are permitted provided that the following conditions are met:

- Redistributions of source code must retain the above copyright notice, this list of conditions and the following disclaimer.
- Redistributions in binary form must reproduce the above copyright notice, this list of conditions and the following disclaimer in the documentation and/or other materials provided with the distribution.
- Neither the name of copyright holder nor the names of its contributors may be used to endorse or promote products derived from this software without specific prior written permission.

THIS SOFTWARE IS PROVIDED BY THE REGENTS AND CONTRIBUTORS ``AS IS" AND ANY EXPRESS OR IMPLIED WARRANTIES, INCLUDING, BUT NOT LIMITED TO, THE IMPLIED WARRANTIES OF MERCHANTABILITY AND FITNESS FOR A PARTICULAR PURPOSE ARE DISCLAIMED. IN NO EVENT SHALL THE REGENTS AND CONTRIBUTORS BE LIABLE FOR ANY DIRECT, INDIRECT, INCIDENTAL, SPECIAL, EXEMPLARY, OR CONSEQUENTIAL DAMAGES (INCLUDING, BUT NOT LIMITED TO, PROCUREMENT OF SUBSTITUTE GOODS OR SERVICES; LOSS OF USE, DATA, OR PROFITS; OR BUSINESS INTERRUPTION) HOWEVER CAUSED AND ON ANY THEORY OF LIABILITY, WHETHER IN CONTRACT, STRICT LIABILITY, OR TORT (INCLUDING NEGLIGENCE OR OTHERWISE) ARISING IN ANY WAY OUT OF THE USE OF THIS SOFTWARE, EVEN IF ADVISED OF THE POSSIBILITY OF SUCH DAMAGE.

Open Source Software Licensed Under the JSON License:

json.org

Copyright © 2002 JSON.org
All Rights Reserved.

JSON_checker
Copyright © 2002 JSON.org
All Rights Reserved.

Terms of the JSON License:

Permission is hereby granted, free of charge, to any person obtaining a copy of this software and associated documentation files (the "Software"), to deal in the Software without restriction, including without limitation the rights to use, copy, modify, merge, publish, distribute, sublicense, and/or sell copies of the Software, and to permit persons to whom the Software is furnished to do so, subject to the following conditions:

The above copyright notice and this permission notice shall be included in all copies or substantial portions of the Software.

The Software shall be used for Good, not Evil.

THE SOFTWARE IS PROVIDED "AS IS", WITHOUT WARRANTY OF ANY KIND, EXPRESS OR IMPLIED, INCLUDING BUT NOT LIMITED TO THE WARRANTIES OF MERCHANTABILITY, FITNESS FOR A PARTICULAR PURPOSE AND NONINFRINGEMENT. IN NO EVENT SHALL THE AUTHORS OR COPYRIGHT HOLDERS BE LIABLE FOR ANY CLAIM, DAMAGES OR OTHER LIABILITY, WHETHER IN AN ACTION OF CONTRACT, TORT OR OTHERWISE, ARISING FROM, OUT OF OR IN CONNECTION WITH THE SOFTWARE OR THE USE OR OTHER DEALINGS IN THE SOFTWARE.

Terms of the MIT License:

Permission is hereby granted, free of charge, to any person obtaining a copy of this software and associated documentation files (the "Software"), to deal in the Software without restriction, including without limitation the rights to use, copy, modify, merge, publish, distribute, sublicense, and/or sell copies of the Software, and to permit persons to whom the Software is furnished to do so, subject to the following conditions:

The above copyright notice and this permission notice shall be included in all copies or substantial portions of the Software.

THE SOFTWARE IS PROVIDED "AS IS", WITHOUT WARRANTY OF ANY KIND, EXPRESS OR IMPLIED, INCLUDING BUT NOT LIMITED TO THE WARRANTIES OF MERCHANTABILITY, FITNESS FOR A PARTICULAR PURPOSE AND NONINFRINGEMENT. IN NO EVENT SHALL THE AUTHORS OR COPYRIGHT HOLDERS BE LIABLE FOR ANY CLAIM, DAMAGES OR OTHER LIABILITY, WHETHER IN AN ACTION OF CONTRACT, TORT OR OTHERWISE, ARISING FROM, OUT OF OR IN CONNECTION WITH THE SOFTWARE OR THE USE OR OTHER DEALINGS IN THE SOFTWARE.